

Permanent implants in treatment of prostate cancer

Marek KANIKOWSKI¹, Janusz SKOWRONEK¹, Magda KUBASZEWSKA¹, Adam CHICHEŁ¹, Piotr MILECKI²

SUMMARY

Received: 17.10.2007
Accepted: 7.07.2008
Subject: review paper

¹ Brachytherapy Department,
Greatpoland Cancer Center,
Poznań

² Radiotherapy Department,
Greatpoland Cancer Center,
Poznań

Address for correspondence:
Janusz Skowronek,
MD, PhD, Ass. Prof.,
Department of Brachytherapy,
Greatpoland Cancer Center,
Garbary Street 15, 61-866 Poznań,
Poland.
Tel. +48 61 8850818,
+48 0602618538 (mobile)
Fax +48 61 8850834
e-mail: janusz.skowronek@wco.pl

Low-dose rate brachytherapy (LDR - BT) is one of the radiation methods that is known for several years in treatment of localized prostate cancer. The main idea of this method is to implant small radioactive seeds as a source of radiation, directly into the prostate gland. LDR brachytherapy is applied as a monotherapy and also used along with external beam radiation therapy (EBRT) as a boost. In most cases it is used as a sole radical treatment modality, however not as a palliative treatment. The application of permanent seeds implants is a curative treatment alternative in patients with organ-confined cancer, without extracapsular extension of the tumour. Nowadays three kinds of radionuclide (I-125, Pd-103, Cs-131) are in use worldwide. This technique is particular favorite in United States, in Europe however, high-dose rate brachytherapy method (HDR BT) is more popular in early staged prostate cancer treatment (as a boost). HDR-BT monotherapy for early stage prostate cancer is still an investigational treatment. As monotherapy LDR-BT seems to be a reliable choice for early stage prostate cancer, according to low morbidity rate good results and short hospitalization. It is curative alternative of radical prostatectomy or external beam radiation (i.e. 3D CRT, IMRT) with comparable long-term survival and biochemical control and most favorable toxicity. The aim of this publication is to describe methods, indications, complications and selected results of prostate cancer LDR brachytherapy.

KEY WORDS: prostate cancer, LDR brachytherapy, radioactive isotope, permanent implants, seeds

INTRODUCTION

Patients with organ-confined prostate cancer are the appropriate candidates for curative treatment. There are several modalities that can be performed in order to treat this kind of cancer, such as: external beam radiation therapy (EBRT), prostatectomy, cryotherapy or interstitial brachytherapy (BT). Brachytherapy is one of the oldest methods and means implantation of radioactive sources directly into the prostate. Permanent low dose rate (LDR) brachytherapy represents the most conformal radiation therapy and the number of patients referred for this radical treatment, grows rapidly, especially in the United States. In 1995 brachytherapy has taken a part in prostate cancer treatment only in 5% (surgery – 65% procedures). Development of new techniques with new computer planning systems caused raising popularity of brachytherapy in US (36% in 2002 and >40% in 2004). Clinical and biochemical control rates of this method is

comparable to radical prostatectomy or EBRT [1], however it is still not easily affordable everywhere because of high procedure costs. There are also several other advantages in LDR-BT. Better toxicity profile with higher dose applying to prostate gland are the main points for brachytherapy in comparison with EBRT. Comparing with radical prostatectomy permanent seed's implantation is a short, one day therapy with lower complication rate during and after the procedure (bleeding, urinary incontinence, impotence). Specific selection of radioactive isotopes and their correct localization, allows to deposit high dose into the prostate tumour with rapid fall off the dose outside the area of treatment and – at the same time – allows to preserve organs at risk (OARs).

The beginning of interstitial brachytherapy as an idea of prostate cancer treatment has been found in the first three decades of XX century. Pasteau and Denning published their data about treatment of patients, with the use

of single application of radium isotope through urethral catheter, directly into prostate gland [2, 3]. Unfortunately, high degree of complications excluded this technique from using it widely and stimulated other centers to look for more efficient modalities.

Another period in history of this procedure can be localized in the 1970s. Permanent implants were placed into malignant tumour after lymphadenectomy under surgeon's vision control. Several centers from US (Whitmore, Carlton) used iodine (I-125) and gold (Au-198) followed by external beam radiation therapy. After long follow-up study they found this method useless, because of unsatisfactory control of seeds position, radioactive danger for department staff and insufficient results in patients with locally advanced disease in comparison with EBRT alone [4].

The development of transrectal ultrasound (TRUS) in the late 80s, caused the emergence of new permanent seeds implantation technique. This procedure was elaborated by Holm and his coworkers using template guidance to help percutaneous needle implantation [5]. Concurrent technology progress including new radioisotopes, afterloading technique and conformal treatment planning, led to a significant turning-point in brachytherapy and yet renewed physician's interest in the procedure of localized prostate cancer treatment. This technique was supported by improved dosimetry and offered the potential advantage by delivering a higher radiation dose directly to the prostate, instead of external beam radiation. Rapid fall in the dose with a square of distance from

the center of the isotope allows the use of doses into the tumour with concurrent protection of adjoin healthy tissues. These main facts permit to increase the concentration of the dose with application of higher, biological equivalent and fraction doses inside the prostate.

LDR-BT, a well-known technique all over the world is usually applied as a monotherapy. The reason why in Poland none of brachytherapy departments uses permanent implants is simple. High cost of an implantation do not transpose into higher 5-year disease-free survival rate of external beam radiation therapy or radical prostatectomy [6,7]. As it was mentioned above, it is still very exclusive form of treatment, where single procedure equals to seven weeks of EBRT with lower rates of late complication rates [8]. Satisfactory results of using LDR implants are possible due to punctilious selection criteria of the patients.

The aim of this publication is to describe methods, indications, complications and selected results of LDR-BT with the administration of permanent implants in prostate cancer treatment.

Indications and contraindications

The American Brachytherapy Society (ABS) has formed recommendations on consensus panel through clinical experience of experts and their analysis of published data. According to their publications the appropriate candidates for LDR monotherapy are patients with a high probability of organ-confined disease (Table 1). In this group with expected good results prescribed doses for low dose rate brachytherapy

Table 1. American Brachytherapy Society recommendations for transperineal permanent brachytherapy of prostate cancer [9]

Selection criteria	BT recommended, good	BT optional, fair	BT investigational, poor
PSA (ng/ml)	< 10	10–20	>20
Gleason score	5-6	7	8-10
Stage	T1c–T2a	T2b–T2c	T3
IPSS	0–8	9–19	>20
Prostate volume (cm ³)	< 40	40–60	>60
Q max (ml/s)	>15	15–10	<10
Residual volume (cm ³)			>200
TURP +			+

IPSS – International Prostate Symptom Score, Q – maximum urinary flow rate in ml/s, TURP – transurethral resection of the prostate

are 145 Gy for Iodine I-125 and 115-120 Gy for Palladium Pd-103 [9].

It is a general agreement not to apply LDR-BT alone on patients with significant risk of extraprostatic extension. Most of physicians defines this group by the presence of at least two main risk factors such as PSA level greater than 20 ng/ml, stage higher than T2b and/or Gleason score greater than 7. According to ABS recommendations, these patients are to be treated with external beam radiation therapy in 40-50 Gy dose with brachytherapy boost of 110 Gy and 100 Gy depending on which EBRT dose was administered [9].

In general intermediate risk group (at least one of the risk factors mentioned above) isn't an absolute contraindication of a single BT modality treatment. Good results published by several authors change the physicians preferences to monotherapy combined with androgen deprivation [10] However, to confirm these observations studies are inevitable.

ABS also recommends LDR treatment in patients with at least 5 years of expected survival rate, what seems to be rather relative contraindication. According to their publication, neoadjuvant androgen deprivation can decrease volume of the gland before brachytherapy [9]. No nodal involvement and absence of distant metastases are basic points in definition of organ-confined prostate cancer. Patients with disseminated disease can not be cured by radical treatment with this kind of radiation modality.

Transurethral resection of the prostate (TURP) is another relative contraindication for brachytherapy and is associated with higher rate (50%) of urinary incontinence after procedure. Nevertheless, several publications did not confirmed these data and proved that risk of this kind of complication is less than 10% [11]. Pubic arch interference as a result of large prostate may preclude adequate placement of seeds, which is the reason why volume of prostate higher than 60 ml seems to be relative contraindication. Potential solution of this difficulty in most cases is hormonal ablation for 3 months before the procedure. It causes less number of seeds during brachytherapy and may achieve their satisfactory distribution. Neoadjuvant hormone deprivation can also reduce significant preoperative obstruc-

tive symptom, which is again a possible serious contraindication for brachytherapy and decrease the probability of postoperative acute urinary retention. Several authors reported that downsizing the prostate gland by 25-40% enables LDR procedure and reduces risk of obstructive complication in patients with large glands [12]. Problem with seeds implantation is likely to occur in obese patients when the equipment is not able to carry the weighty patients or is it not long enough to reach the base of prostate. Serious cardiac and respiratory tract diseases are not contraindications for brachytherapy and nowadays having not much of a significance. It may, however be noted that every older patient with these kind of problems requires more attention of physicians. Indications and contraindications according to ABS and ESTRO recommendations are summarized in table 2 a and b.

Choosing isotope

There are several isotopes that are in use in medical world and each of them have unique energy and half life time. These physical characteristics determine the application of isotopes in two modalities in brachytherapy of prostate cancer - temporary (HDR) or permanent implants (LDR). Higher energy of an isotope equals better penetration into target tissue and according to that fact, the location of single source in homogeneous dose achievement is not that important. On the other hand, the greater penetration of source radiation - the less protection of healthy tissue and higher degree of complication rate as well as the necessity of reducing total dose to target volume. Ir-192 and Au-198 are the best examples of high energy radiation sources, which are potentially useful in brachytherapy as temporary implants. Low dose rate (LDR) energy sources such as I-125 or Pd-103, due to limited penetration, deposit prescribed dose into prostate gland with precision and sparing surrounding healthy tissues at the same time [13]. Because of this precised radiation, the LDR implants must be located with significant caution to avoid areas of under dosage. Low dose rate energy allows the target to receive very high dose (120-160 Gy) of radiation at a longer time. This should be compared biologically to HDR monotherapy dose in shorter time

Table 2. Indications (a) and contraindications (b) for permanent implant monotherapy according to ABS and ESTRO recommendations [9]

	Table 2 a	
Selection criteria	ABS	ESTRO
PSA (ng/ml)	<10	<10
Gleason score	2–6	5–
Stage	T1–T2a	T1c–T2a
AUA/IPSS	Low (1–7)	0–8
Prostate volume (cm ³)	< 60	<50
Q max (ml/s)	–	>15
Residual volume (cm ³)	–	<200
TURP +	–	–
	Table 2 b	
Selection criteria	ABS	ESTRO
Life expectancy	<5 years	<5 years
TURP	Large and poorly healed defect	Exclusion criteria
Distant metastases	+	+
Gland size (cm ³)	>60	>50
BPH	– (Relative contraindication)	–
Pubic arch interference	+ (Relative contraindication)	+ (Relative contraindication)
Bleeding disorder	–	+
Positive seminal vesicles	– (Relative contraindication)	–

IPSS – International Prostate Symptom Score, Q – maximum urinary flow rate in ml/s, TURP – transurethral resection of the prostate, BPH – benign prostate hypertrophy

but with higher dose rate. Biologically higher dose can be given by HDR monotherapy but only with fractionation. The need of external beam therapy depends on the risk of extracapsular extension. With HDR monotherapy one could also give sufficient dose to the prostate and can omit external beam therapy. Figure 1 presents example of one permanent implant, figure 2 presents construction details of the I-125 implant.

I-125 has a low energy (27 keV) with initial peripheral dose rate of 8 to 10 cGy/hr and a half-life of 60 days. According to this dose rate there have been several questions about effectiveness of permanent implants (specially I-125) in treatment of rapidly dividing tumours. Less differentiated malignancies with short half-lives may proliferate faster than reducing tumor cells by I-125 treatment, which was proved by Freeman and his co-

workers in experiments [14]. There have been also several mathematical models constructed which compared degree of cell kill in relation with tumor doubling times for each radiation source. Moreover, Whitmore and al. published data that reveals the effectiveness and comparison of LDR and HDR implants of cell killing in rapid dividing tumors [15]. According to their studies, low-dose-rate permanent implants are not so effective in this process as the HDR sources.

From 1986 new isotope – palladium 103 is in use in medical treatment. This radioactive source has almost the same physical characteristics (energy – 21 keV) as the I-125. The main difference between Pd-103 and I-125 is shorter half-life of palladium (17 days) and that causes it's initial dose rate higher of about 20 cGy/hr. Few clinical data about this new isotope presents the theoretical advantage of us-



Fig. 1. Permanent implant used in brachytherapy

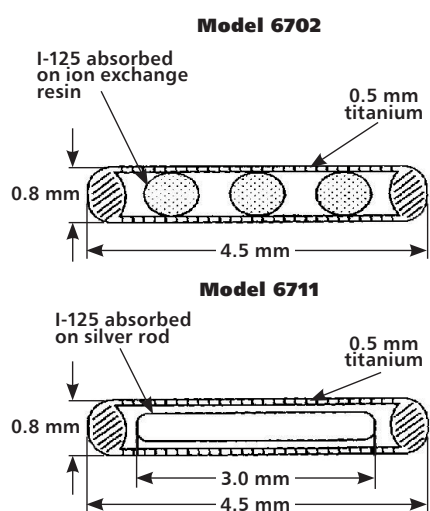

Fig. 2. Examples of I-125 implants used in brachytherapy

ing palladium 103, along with radioprotection of medical workers (LDR) and high possibility of successful treatment in rapidly dividing tumors (all comparing with I-125) [13]. That is a reason why Pd-103 should be the choice in presence of poorly differentiated prostate gland malignancies. Changing of treatment

into high-dose-rate temporary brachytherapy is well advisable. All this theoretical data needs to be verify by clinical multivariate trials. However, there are little data on the proliferation rate of human prostate cancer to confirm this, nor any randomized trial data to show that one isotope is any better than the other.

Another isotope, Cesium-131 (Cs-131) was introduced at leading cancer treatment hospitals in United States in October 2004 [16]. This isotope has been used in almost 50 locations across the US because of its useful characteristics in prostate cancer treatment. Cesium-131 transmits radiation dose to the target faster than other isotope seeds mentioned above. Thanks to that it became possible for patients to receive higher initial therapeutic dose with faster process of cancer cell killing. Shorter radiation treatment can have an impact on complications time duration (reduced chances of normal tissue exposure) in comparison with other isotopes [16]. 90% of therapeutic dose is being deposit in 33 days in more homogeneous way with less total radiation to the patients. Moreover, relatively high energy level (29 KeV) provides 30% of greater penetration of prostate tumor, if compared with palladium-103. It is also very important for patients, that short half- life of Cs-131 (only 7-9 days) causes shorter restrictions of radiation exposure for dormitories and environment [16, 17]. The comparison of physical characteristics of all these most popular isotopes has been made in Table 3. Tables 4 and 5 presents detailed decay data of I-125 and Pd-103.

Despite biological models and better knowledge of radiosensitivity of tumors and normal tissue there are insufficient data to definitely decide which isotope is more effective in

Table 3. Physical characteristics of used permanent implants

Isotope	Half life	Energy	90% of dose delivered	Dose Range (Median dose)
Iodine-125	60 days	30.4 KeV	204 days	1. monotherapy 140-160 Gy (145 Gy) 2. BT + 40-50 Gy EBRT (100-120 Gy)
Palladium-103	17 days	22 KeV	58 days	1. monotherapy 110-120 Gy (125 Gy) 2. BT + 50 Gy EBRT (60-90 Gy)
Cesium- 131	9.7 days	29 KeV	33 days	1. monotherapy (115 Gy)

- I-125 8 cGy/h (initial dose rate) 144 Gy in 10 months (total dose per time)
 - Pd-103 24 cGy/h (initial dose rate) 125 Gy in 3 months (total dose per time)

Table 4. I-125 Decay Table

I-125 Decay		
Days	Comment	% I-125 Remaining
0	Implant Day	100
7		92.2
14		85.1
21		78.5
28		72.4
35		66.7
42		61.6
49		56.8
56		52.4
60	1 st Half Life	50
63		48.3
70		44.5
77		41.1
84		37.9
91		34.9
98		32.2
112		27.5
120	2 nd Half Life	25
150		17.8
180	3 rd Half Life	12.5
198		10
240	4 th Half Life	6.25
300	5 th Half Life	3.125
360	6 th Half Life	1.5625
396		1.0

Table 5. Pd-103 Decay Table

Pd-103 Decay		
Days	Comment	% Pd-103 Remaining
0	Implant Day	100
2		92.5
4		85.5
6		79
8		73
10		67
12		62
14		57
16		52
17	1 st Half Life	50
18		48
20		44.5
22		41
24		38
26		35
28		32
30		29.5
32		27
34	2 nd Half Life	25
36		23
38		21
40		19.5
42		18
44		16.6
46		15.2
48		14
50		13
51	3 rd Half Life	12.5
54		11
57		9.7
60		8.6
64		7.3
68	4 th Half Life	6.25
75		4.7
85	5 th Half Life	3.125
90		2.5
102	6 th Half Life	1.5625
112.5		1

prostate cancer treatment. There is no clear agreement between the scientists about alpha/beta value which is useful in calculating biological dose. Prospective clinical studies comparing HDR and LDR monotherapy are ongoing but most of authors established alpha/beta ratio as 1,5. According to this value for acute effects we can calculate that HDR brachytherapy is much more effective for lower alpha/beta values. For the higher one seed's therapy seems to be a better choice for patients (higher biological dose applied). Apart from that, the biologic effectiveness of the radiation treatment strongly depends on dose rate and the radiosensitivity of the tissue. It is well-known fact that higher dose rate apply

equally great damage to both healthy and malignant cells of an organism. According to this significant information, the knowledge about dose rate impact on biologic cell cycle, influences the physicians to select the modalities of treatment (HDR or LDR) as well as the sort of radioactive sources [13].

The comparison of temporary and permanent implants

Two brachytherapy treatment modalities (LDR and HDR) can be only compared in monotherapy in patients with low staged tumors. In most cases LDR-BT is administered as a single treatment in early detected prostate cancer. High-dose-rate (HDR-BT) brachytherapy is usually applied along with external beam irradiation to patients with prostate tumors not qualified by strict stage terms. HDR-BT is relatively new as a monotherapy and at the moment there is limited data about the results and the complication rates in this indication [18,19]. In some publications HDR as radiation modality has ability to deposit higher dose to the tumor and lower dose to organs at risk [18]. It produces more inhomogeneous dose distribution in the target (higher V150 and V200 parameters) but due to flexibility of planning, inhomogeneity can be used to keep the dose of organs at risk low while increase the dose on the periphery of the gland. Because of impossibility to remove or adjust permanent seeds, there is no way to compensate isodose by computer planning system after implantation. Moreover, it is advisable to use high-dose rate brachytherapy in prostate cancer, suspected of extracapsular spread, in order to achieve better coverage of this area, if compared with gland only targeted seeds therapy, because seed migration can be significant problem in this case. Apart from the dosimetry the larger dose per fraction seems to respond better in local control of prostate cancer treatment. According to radiobiological considerations, the use of HDR-BT in these kind of tumors is far more practical [18]. After temporary HDR-BT there is no restrictions about patients radioactivity and possibility of seeds migration through the bloodstream outside the gland. Oedema's therapeutic dose coverage trouble does not exist in temporary implantation procedure because of real time planning and short treatment time.

There are also some positive aspects about using LDR-BT in radiation oncology. Patients with cancers at early stage are able to attend one day procedure in surgery with all cost profits according to this fact. In United States single LDR-BT costs much less than EBRT along with HDR-BT. The comparison of time duration in these two modality treatments is another serious plus point of using seeds therapy (one day versus 4–5 weeks). This technique has yet another strong argument – many cancer centers has a lot of experience in performing permanent implants, usually about 5 years longer than modern HDR prostate brachytherapy. Wide availability of this treatment and its frequent performing, give rise to increased number of publishing data with generally good results in treatment of organ confined prostate cancer [19]. Seeds implants therapy, performed by experienced brachytherapist, gives almost the same quality of glands dose coverage as the temporary implants technique. Summarized comparison of both brachytherapy techniques was presented at ASTRO Meeting in Phoenix, 1998 (Table 6).

Implantation technique

Preoperative workup before low-dose-rate seeds insertion includes mechanical bowel preparation, prophylactic intravenous antibiotics, continued per os for several days afterwards. Before the procedure patients with history of deep vein thrombosis is being given heparin subcutaneously to prevent any complications in connection with these blood condition. Because of significant risk of perineal haemorrhage, the rest of the procedure candidates are to stop receiving anticoagulants, including aspirin, nonsteroidal anti-inflammatory drugs or warfarin [20]. In the operating room, a patient is placed under general or spinal anesthesia in dorsal lithotomy position. After catheterization of contrast (Renografin) or air filled gel that are usually used to visualize the urethra and to differentiate the bladder from the prostate. It is also important to exclude scrotum and testis from radiation field by fixing them with tape or towel clips. First step of the procedure is the necessity of determining the shape and size of the gland before needles insertion by initial trans-rectal ultra-

Table 6. Comparison of high-dose-rate temporary implants and permanent seed implants

The following table was compiled by the HDR Prostate Working Group and presented to radiation oncologists at the American Society of Therapeutic Radiology and Oncology (ASTRO) meeting in Phoenix, October 1998.

	High Dose Rate	Permanent Seed
Conformal treatment	++++	++++
Target accuracy	++++	++++
Ability to treat extracapsular extension	++++	+
Ability to treat seminal vesicles	++++	++
Ease of control of radiation	++++	++
Lack of cold/hot spots	++++	++
Control of critical organ dose	++++	++
Modify dose distribution	++++	+
Need for external beam	yes/sometimes	no/sometimes
Monotherapy	+	+++
Experience of physician	crucial	crucial
Pre-planning dosimetry	not needed	extensive (TRUS)
Post-implant dosimetry	not needed	extensive (CT)
Stages treated	all, T1–T3	T1–T2
Gland volume > 60 cc at time of implant	less difficulty	more difficulty
Pubic arch interference at time of implant	less of a problem	can't be done
Prior TURP	less of a problem	can't always be done
Final dose verification	pre-treatment	post-treatment
Symptom duration	weeks	months
Implant cost	higher	lower

sound examination (TRUS). It can be done a few weeks before seeds insertion (preimplant treatment planning) or can be performed on the day of the procedure (intraoperative treatment planning). A biplanar probe at 5, 6, or 7.5 MHz of frequency, gather ultrasound visualization of prostate localization at 0,5 cm intervals, compared with the one after needles insertion. Treatment plan prepared should contain several informations such as a needle location, number and strength of seeds and shape and volume of the target. To achieve exact dose inside the prostate there is necessity to use nomograms (inadequate amount activity per volume) combined with real-time TRUS and treatment planning system.

Transrectal ultrasound equipment is combined with special template used for seeds implantation and by guiding creates stepping unit. Before proper procedure it is important to measure the distance from bladder base to

template. Only then, two stabilising needles are being inserted through the template just posterior to the urethra on either side of the midline [21]. Because of movement of the prostate, during the procedure a pre-plan is created in order to minimize the risk of positioning errors. The loading pattern indicate co-ordinates in the computer planning system in connection with the templates stepping unit [21]. That gives the physicians exact points to insert each needle and number of seeds. When the pre-plan is done 20 cm long 18 gauge needles are inserted and after consulting two plans (before and after insertion) radioactive seeds are placed into the prostate gland through Mick applicator (loose seeds technique). The schema of patients positioning and implantation technique is presented in Figure 3. (Figure 3) Withdrawing each needle should be done very carefully to avoid source migration inside the gland. Once the procedure has

been completed, the position of implants must be observed under fluoroscopy and ultrasonography. Usually there is no possibility of removing seeds after insertion and if a “cold spots” are observed, a few extra seeds can be added to cover them. Performing a final CT scan of the prostate and postimplant dosimetry ends up the whole procedure of LDR seeds implantation in prostate cancer treatment. The patient leaves the theatre catheterized and after removing it, can be discharged home the next day [20]. Schematic positioning of implants is presented in Figure 4 a and 4 b, radiogram with visible implants – in Figure 5. There is another advanced technique of seeds implantation worth of mentioning. In stranded seeds technique the point is to implant radioactive sources embedded in a polymer strand of glycolide, lactide and polydioxanone spaced from 5 mm to over 50 mm apart and placed in 18-gauge needle. The main advantages of this technique using is significant improvement in D90 parameter without increase of toxicity rate and less number of seeds migration incidences [22].

Dosimetry

Apart from dosimetric planning of the implant before or during seed insertion, American Brachytherapy Society (ABS) recommends postimplant dosimetry in all patients for best optimal care [9]. According to availability, cost and exact way to visualize a prostate with implanted seeds, CT-based dosimetry is in the world-wide use nowadays. CT scanning has to be determined by each center at a consistent postoperative intervals to check the evalu-

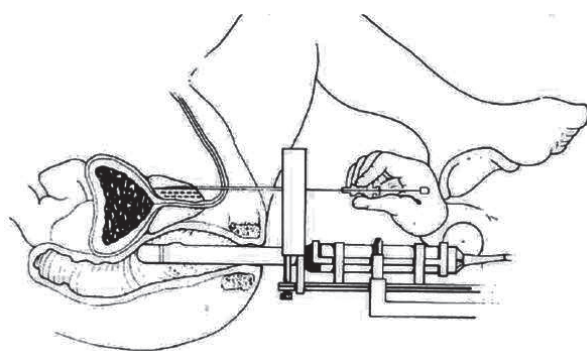

Fig. 3. Setting the needles using permanent implant technique

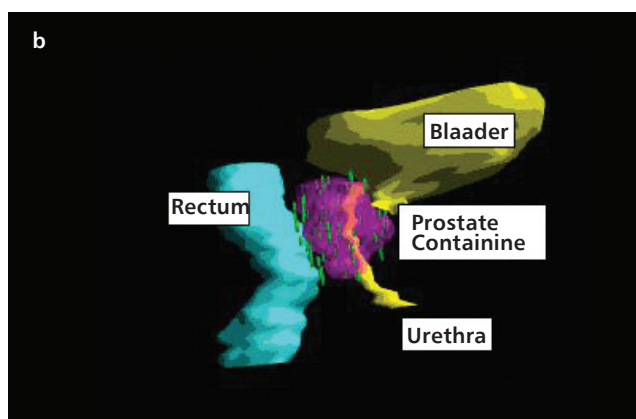
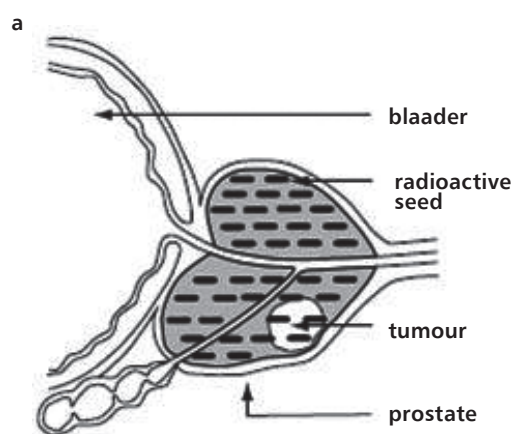

Fig. 4 a i b. Schematic images of implants and circumja-cent Organs at Risk (OAR) – Blaader, Urethra, Rectum

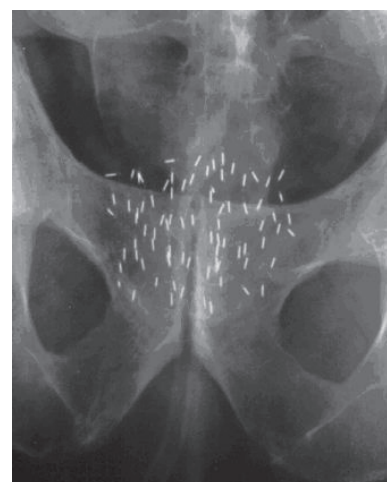

Fig. 5. X-ray image of implanted I-125 implants [20]

ation of implanted seeds position and this intervals should be reported [20]. On every digital examination physicians with physicist should obtain isodoses overlapping the gland

at 50%, 80%, 90%, 100%, 150%, and 200% of the prescribed dose and compared with dose-volume-histograms (DVH) on previous CT scans. Nevertheless, ABS recommends for all centers to perform DVH and report the D90 value (dose received by 90% of the target volume) and the V 100 (volume received 100% of the prescribed dose) [9]. To prevent any serious complication of organs at risk (OAR) the rectal and the urethral doses should be reported and correlated with patient ailments during the interview. In addition to the treatment, post implant radiographs can be performed to verify the seeds location and their number. The dose is usually prescribed at the periphery of the target volume and for J-125, Pd-103 – it equals to 145, 125 Gy, respectively. The prescribed dose in the centre of radiated volume should not be higher than 150%, what can be achieved by decreasing the number of seeds from potential “hot-spots” [21]. Oedema of the gland after implantation procedure is the last point worth of mention in this paragraph. Higher volume of prostate causes worse value of therapeutic dose cover. Using treatment margin value (TM) in treatment planning should help to cover exact volume of the gland. Anyway, role of treatment margin around the prostate is to cure possible microscopic disease spread outside the capsule. TM in most cases should equal not less than 3-5 mm and in many publications [23]. Example of treatment plan is presented in Figure 6.

Selected outcomes presentation

Several authors publishing their data in medical periodicals generally confirmed good results in prostate cancer treatment by LDR-BT alone. Implantation of low-dose-rate seeds in most cases is used as a single modality treatment with or without concurrent androgen deprivation. The main reason of problems in comparison between published series are: selection criteria, nonuniformity of end points, different follow-up times and hormonal therapy used by medical centers worldwide. Publication data with longer follow-up are known as the most authoritative results (about 5 years). Authors from Memorial Sloan-Kettering Cancer Center reported the 5-year tumor control and toxicity outcomes for patients with localized pros-

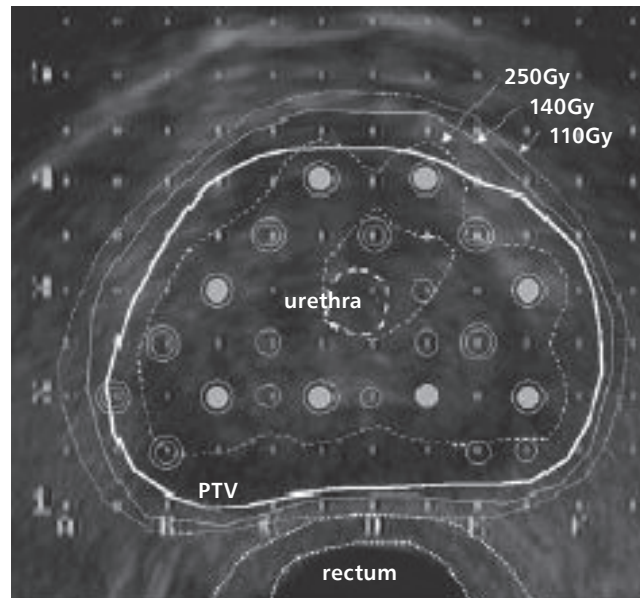

Fig. 6. Image assisted treatment planning in prostate cancer. Transverse ultrasound image showing the PTV, Urethra and Rectum delineated and the dose distribution in a LDR Iodine permanent implant. Isodose levels are given for the prescribed dose of 140 Gy as well as for 250 Gy and 110 Gy. [20]

tate treated with I-125 permanent implantation [32]. The amount of 2693 patients with prostate cancer were treated between January 1998 and June 2002 with LDR-BT alone by using real-time intraoperative treatment planning system. The 5-year PSA relapse-free survival rates for low and intermediate risk patients – according to the ASTRO definition – were 96% and 89%, respectively. The authors stated that D90 was correlated to 8 year PSA relapse free survival (PRFS). On multivariate analysis in patients with post-implant dosimetry D90 was a significant predictor for PRFS. There is an agreement that parameter D90 needs to be reported in seed publication. Acute urinary symptoms had 38% of patients, but within a median time of 6 months, 63% of them have been relieved from these symptoms. The late rectal toxicity was noticed at 1%, late rectal bleeding (Grade 2) at 7%. Apart from good biochemical control outcomes this publication demonstrated that real-time planning methods can consistently and reliably deliver the intended dose distribution to achieve an optimal therapeutic ratio between the target and normal tissue [32].

Five European countries (France, Finland, Italy, Spain and the UK) have gathered their data in interstitial LDR treatment of prostate cancer as a monotherapy and published it in July 2006. Between May 1998 and August 2003, the number of 1050 patients with localised disease in stage T1-T2 were treated by brachytherapy [33]. They were divided into three main risk groups (ASTRO definition) with percent disposition of 63.6%, 28.3%, 6.3% respectively. Unfortunately from whole number of patients only 364 of them were evalu-

able by the Kaplan-Meier method for determining freedom from biochemical failure in 36 months time. The biochemical progression-free rate at 3 years for each: low, intermediate and high risk groups, was noticed at 93%, 88%, 80% respectively. Although in this publication authors reports preliminary data, the outcomes of LDR monotherapy were gathered from different medical centers and after statistic evaluation, confirmed good results depending on stratification into risk groups [33]. Merrick et al. from April 1995 to October 2002

Table 7. Treatment results of LDR-BT monotherapy published by different authors

Author	Number of patients	Risk group	Treatment schedules(monotherapy)	Follow-up	Results
Guedea F [33]	364	I, II, III	LDR BT (results of 4 centres)	36 months	BC 93.0% I 88.0% II 80.0 III
Bladou F [36]	260	I, II, III	LDR BT (I-125)	29.5 months	DFS 93.8% (all groups) 97.7% (I).
Radge H [37]	619	I, III	LDR BT I-125 (I) Pd-103 (III)	13 years	DFS 76% I 80% III
Sharkey J [38]	166	I	LDR BT Pd-103 + HT	5 years	FFPF 86%
Merrick GS [39]	32	I, II, III	LDR BT	26.4 months	BC 100%
Kollmeier MA [40]	243	I, II, III	LDR BT (I-125, Pd-103) + HT	8 years	FFPF 88.0% I 81.0% II 65.0% III
Prada PJ [41]	275	I, II, III	LDR BT (I-125, Pd-103)	5 years	96% OS 97% DFS 99% BC
Merrick GS [42]	119	I, II, III	LDR BT	7 years	BC 93.1% I 100.0% II 95.2% III
Stock RG [43]	79	I, II	LDR BT (I-125, Pd-103)	24 months	FFPF 76%

BC – biochemical control rate, DFS – progression-free survival rate, OS – overall survival, FFPF – freedom from PSA failure rate

Risk groups:

I (TNM cT1–cT2a, Gl < 6, PSA < 10 ng/ml)

II (TNM cT2a–cT2c, Gl 7, PSA 10–20 ng/ml)

III (TNM > cT3, Gl 8–10, PSA > 20 ng/ml)

LDR BT – low-dose-rate brachytherapy

HT – androgen deprivation therapy

gathered data about outcomes (biochemical progression-free survival-BPFS) in hormone-naive men aged <54 years who underwent brachytherapy with or without external beam radiation therapy [34]. The patients (n=108) without hormonal treatment were treated with low dose rate interstitial brachytherapy for clinical stage T1C-T2C N0M0. The mean observation time was 5,3 years for all patients. No patient had a seminal vesical biopsy or pathological lymph node staging. BPFS was defined by a prostate-specific antigen (PSA) level of less or equal 0,4 ng/ml after the nadir. Patients were assigned to risk groups according to Memorial Sloan-Kettering Cancer Center criteria. Several clinical, treatment and dosimetric parameters were analysed for their effect on BPFS. After observation time, authors observed that for the entire group the actuarial 8-year biochemical progression-free survival rate was 96%, for the low-risk was 96% for the low-risk group, 100% for the intermediate-risk, 75% for the high-risk group. For patients without any biochemical relapse (biochemically disease-free), the median PSA level was 0,05 ng/ml. In a multivariate analysis, only pretreatment PSA level predicted biochemical control, while dosimetry variables after treatment were almost statistically significant. It is important to take into consideration the fact of observing excellent results with brachytherapy in patients with low and intermediate risk disease and significant worse in higher risk group. Apart from that hormone-naive patients aged less or equal 54 years have a high probability of good 8-year BPFS after permanent interstitial brachytherapy with or without EBRT [34].

Schiffler Cancer Center in West Virginia published an article about outcomes in prostate cancer treatment at hormone-naive patients with high-risk disease after permanent prostate brachytherapy [35]. Sixty-six men underwent LDR-BT with the use of either Pd-103 or I-125 from April 1995 to October 1999. Brachytherapy boost was preceded by supplemental external-beam radiation therapy in most of them (98,5%) without additional androgen therapy. After different follow-up time (ranged 19.8 - 79.7 months), authors established the 5-year actuarial biochemical disease-free survival rate as 79.9% (defined by ASTRO con-

sensus definition). Moreover, Merrick with his coworkers found out that preimplantation level of PSA was the only treatment parameter that predicted biochemical failure. These results proved that more or less hormone-naive patients with high-risk disease have a high rate of 5-year biochemical disease-free survival after combined radiation therapy alone [35]. Tables 7 and 8 show selected results about permanent brachytherapy and external beam radiation therapy in several publications.

Complications

Rapid development of new computer planning systems and the use of modern technology are very helpful to upgrade the quality of treatment. However, it is not possible to avoid certain complications after implantation procedure. In the first 24 hours after therapy it is frequent to observe haematuria. Urinary symptoms are the most common side effects of the LDR brachytherapy. Symptoms such as a dysuria, frequency or urgency urinating and especially an inability to empty the bladder completely, may occur and last in various cases even up to several weeks. These irritative acute symptoms can be relieved by alpha blockers, anti-spasmodic or inflammatory drugs and eliminated in some patients over time. If the bladder cannot be emptied for longer period of time, temporary self-catheterization may be helpful to insure proper drainage. Nevertheless, 34-45% of patients notice urinary symptoms from 0,5-1 year after seeds implantation [20].

Transurethral resection of the prostate (TURP) followed by LDR-BT may increase the risk of urinary incontinence in such patients. The incidence rate of incontinence is 10-35% in the first few months, with few patients having any leakage in 1 year [20]. In the other publication authors reported development of the symptoms risk less than 10% [11]. Determining of volume mass of the gland by ultrasound visualization before the procedure can minimize the risk of this symptoms afterwards. Urethral stricture occurs in 3-6% of patients and may require urethral dilatation.

Rectal complications are reported in more or less 30% of patients include painful bowel movements, urge and diarrhea. In the first year these symptoms become less severe and

Table 8. Results of treatment combination (EBRT plus LDR-BT) published by different authors

Author	Number of patients	Risk group	Treatment schedules(monotherapy)	Follow-up	Results
Wallner K [44]	112 (risk group I)	I, II, III	EBRT (44 Gy) + Pd 103 (90 Gy) v EBRT (20 Gy) + Pd-103 (115 Gy)	3 years	84% DFS 94% DFS
Sylvester JE [45]	223	I, II, III	EBRT (45 Gy) + I-125, Pd-103	15 years	BFFS 88% (I) 80% (II) 53% (III)
Sherertz T [46]	156	II, III	EBRT (44 Gy) + Pd 103 (90 Gy) v EBRT (20 Gy) + Pd-103 (115 Gy)	3 years	overall DFS 86%
Stock RG [47]	43	III	HT + EBRT + Pd-103	4 years	FFPF 74%
Orio P [48]	179	II, III	EBRT + Pd-103	3 years	overall DFS 79%
Peschel RE [49]	68	I, II, III	EBRT (45 Gy) + I 125 (110 Gy) v EBRT (45 Gy) + Pd-103 (98 Gy)	5 years	72% DFS 74% DFS
Merrick GS [50]	668	I, II, III	HT + EBRT + Pd-103, I-125	8 years	DFS 98.2% (I) 98.4% (II) 88.2% (III)

FFPF – freedom from PSA failure rate, DFS – progression-free survival rate, FFPF – freedom from PSA failure rate, BFFS – biochemical failure survival rate

Risk groups:

I (TNM cT1– cT2a, G1 < 6, PSA < 10 ng/ml)

II (TNM cT2a–cT2c, G1 7, PSA 10–20 ng/ml)

III (TNM > cT3, G1 8–10, PSA > 20 ng/ml)

EBRT – external beam radiation therapy

HT – androgen deprivation therapy

after that time only 2% of cases have it persistent [20]. Rectal bleeding can be observed at 1- 20% of patients depending on published data. Prostatorectal fistulas occur in 0,5-1% of all patients in published series [20,21,25]. In addition, ulcerations on the anterior rectal wall overlying the prostate after LDR-BT procedure can be associated with increased rate of fistula formation [24]. As a biopsy findings, 1% of patients can developed proctitis which was observed by Blasko et al. after I-125 seeds implantation [8].

In 33% of patients, LDR brachytherapy can cause complications in sexual functions and activity with concurrent decrease of semen volume. In several reports the problem of impotence is not significant in comparison with sexual disorders after radical prostatectomy

[26]. Generally 2,5-20% of patients can suffer from this kind of problem but they can usually be helped with Viagra and other drugs or devices. Moreover, Wallner et al. after three years of observation noticed that potency can be maintained in 81% of men [27]. Kaye et al reported degree of potency decrease one year after procedure in 75% of patients [28]. Sexual disfunctions after radical prostatectomy and this rather permanent condition is a well known complication.

Several publications in the medical literature treats about seeds migration in few months after implantation procedure [29,30]. Stone and al. examined 238 patients that underwent implantation with either I-125 or Pd-103 and applied a routine chest x-ray every 4 months after procedure. For total of 21,654

implanted seeds only 10 (0.005%) were found in the lungs of 4 patients who also underwent embolus disease [29]. Although, the frequency of this complication event is rather rare, physicians should always consider the possibility of postimplant seeds migration in the whole body. Selected complication data published by several authors have been gathered in table 9.

Patient's care and follow up

The Foley catheter can be removed approximately in the next day after procedure, when urine ability of patient is good enough and there is no signs of active haemorrhage. It is recommended for a patient to drink plenty of fluids for the first two days after treatment to

prevent serious infections of urine pass. To reduce the swelling of perineum caused by the needles, applying of a ice pack seem to be a good idea. Because of the risk of seeds lose during urination or sexual act, patients should be receiving a special packet home to protect other people from LDR radiation. During sexual intercourses, patients must remember about the need of using condoms within two months. The necessity of keeping away children or pregnant women for two months after procedure is a basic point in environment radiation safety. I-125 emits very low-dose-rate energy radiation and it is stopped inside the target in most cases [31]. In addition, prolonged close contact with young children and

Table 9. Complications of prostate cancer LDR treatment in different publications

Author	Treatment schedules	Rectal dysfunction	Urinal dysfunction	Sexual dysfunction	Median follow-up
Shah MD [51]	LDR (I-125 145 Gy or Pd-103 120 Gy) +/- HT	Acute toxicity: Proctitis grade I 5.3% Incontinence grade I 5.3% Haemorrhage grade I 8.3% Diarrhoea 16.7%	ND	ND	41 months
Merrick GS [52]	LDR (I-125 145 Gy or Pd-103 120 Gy)	ND	ND	Potency preservation rate 50.5%	36 months
McElveen [53]	LDR I-125 145 Gy	ND	Incontinence Grade 1 26% Grade 2 5%	ND	47 months
Bettermann J.J. [54]	LDR I-125 145 Gy	Intestinal problems 1.6% Rectal ulcer 0.4 %	Urinary complications 7.23% (including acute retention 1.6%, urethral strictures 1.2 %)	ND	29.2 months
Blank L [55]	LDR I-125 160 Gy +- EBRT 40 Gy	Proctitis, bleeding 3.92% Nausea, vomiting 5.88%	Urinary incontinence 0.98% Stricture 1.96% Acute retention 4.9%	48% Potency preservation rate	102 months
Blasko JC [56]	LDR (I-125 145 Gy or Pd-103 115 Gy) + EBRT 45 Gy	Grade 2 6% Grade 3 2% Recto-urethral fistulas 0.5%	ND	ND	58 months
Salem N [57]	LDR I-125 144 Gy	ND	Grade 1 34% Grade 2 10% Grade 3 16.7%	ND	14 months
Keyes MD [58]	LDR (I-125 144 Gy +/- HT +- TURP.	ND	acute urinary retention 12.7% prolonged urinary obstruction 5%	ND	39.1 months

ND - no data in publication, TURP - transurethral prostate resection.

pregnant women is not eliminating any potential radiation risk for them. Patient should be discharged home with five days continuation of antibiotics or analgesics. To prevent any urinary troubles according to glands postprocedure oedema, corticosteroids and/or non-corticosteroids antiinflammatory drugs can be used for several days.

Blood test (PSA) is performed once in each month after LDR brachytherapy for a patient follow up. The CT Scan is used to control seeds positions inside the prostate and to visualize isodoses that encompasses it. Postimplant planning and dosimetry based on CT made after 4-6 weeks after the procedure is of importance with regard to the quality of the implant. The chest X-Ray is a digital examination to check if any seeds have escaped from the target to lungs via bloodstream. A physical examination and a blood test are repeated by urologist and radiation oncologist once every three months. It is also possible to check cancer regression by transrectal biopsy, two years after the implantation [59].

CONCLUSIONS

Application of low-dose-rate permanent implants in localized prostate cancer has established its importance worldwide. LDR-BT is a major competition nowadays with radical prostatectomy in early detected tumors, especially in older men. As a single modality treatment procedure has been applied in patients from low risk group without any risk of extracapsular extension. Combination of brachytherapy with external beam radiation therapy can be useful in higher risk groups with addition of androgen ablation therapy. In most cases brachytherapists use two kinds of encapsulated isotopes in prostate cancer therapy: Iodine-125 and Palladium-103. However, good results and more convenient therapy for the patients, this method is still an exclusive modality treatment, because of its high cost of single procedure. Anyway similar cost-effectiveness fact of external beam radiation, radical prostatectomy and seeds therapy should be highlight here [60]. We think that for patients, it is much more desirable to spend only three hours in an outpatient surgical clinic for a seed implantation than to undergo major abdominal or perineal surgery, that requires weeks

of recovery, or in other case – to submit a patient for protracted daily radiation treatments which last for several weeks. Favorable toxicity profile of permanent implants brachytherapy in comparison with all established curative modalities particularly to sexual function makes it an effective weapon of prostate cancer treatment.

REFERENCES

- 1 Machtens S, Baumann R, Hagemann J et al. Long-term results of interstitial brachytherapy (LDR-Brachytherapy) in the treatment of patients with prostate cancer. *World J Urol.* 2006; 24(3): 289–95.
- 2 Pasteau O. Traitement du cancer de la prostate per le Radium. *Rev Malad Nutr* 1911; 363–367.
- 3 Denning CL. Carcinoma of the prostate seminal vesicles treated with Radium. *Surg Gynecol Obstet* 1922; 34: 99–118
- 4 Morton JD, Peschel RE. Iodine-125 implants versus external beam radiation therapy for stages A2, B, C prostate cancer. *Int J Radiat Oncol Biol Phys* 1988; 14: 1153–1157.
- 5 Holm HH, Juul N, Pedersen JF et al. Transperineal I-125 seed implantation in prostatic cancer guided by transrectal ultrasonography. *J Urol* 1983; 130: 283–286.
- 6 Fuks Z, Leibel SA, Wallner KE et al. The effect of local control on metastatic dissemination in carcinoma of the prostate: Long-term results in patients treated with I-125 implantation. *Int J Radiat Oncol Biol Phys* 1991; 21: 537–547.
- 7 Morton JD, Peschel RE. Iodine-125 implants versus external beam therapy for stages A2, B and C prostate cancer. *Int J Radiat Oncol Biol Phys* 1988; 14: 1153–1157.
- 8 Blasko JC, Radge H, Schumacher D. Transperineal percutaneous iodine-125 implantation for prostate carcinoma using transrectal ultrasound and template guidance. *Endocurietherapy Hyperthermia Oncology* 1987; 3: B1–B9.
- 9 Nag S, Beyer D, Friedland J et al. American Brachytherapy Society (ABS) recommendations for transperineal permanent brachytherapy of prostate cancer. *Int J Radiat Oncol Biol Phys* 1999; 44(4): 789–99.
- 10 Merrick GS, Butler WM, Galbreath RW et al. Biochemical outcome for hormone-naive patients with Gleason score 3+4 versus 4+3 prostate cancer undergoing permanent prostate brachytherapy. *Urology* 2002; 60(1): 98–103.

- 11 Wallner K, Lee H, Wasserman S, Dattoli M. Low risk of urinary incontinence following prostate brachytherapy in patients with a prior transurethral prostate resection. *Int J Radiat Oncol Biol Phys* 1997; 37(3): 565–9.
- 12 Lee WR. The role of androgen deprivation therapy combined with prostate brachytherapy. *Urology* 2002; 60(3 Suppl 1): 39–44; discussion 44.
- 13 Porter AT, Blasko JC, Grimm PD et al. Brachytherapy for Prostate Cancer. *Cancer J Clin* 1995; 45: 165–178.
- 14 Freeman ML, Goldhagen P, Sierra E, Hall EJ: Studies with encapsulated Iodine-125 sources. *Int J Radiat Oncol Biol Phys* 1982; 8: 1335–1361.
- 15 Whitmore WF. Interstitial implantation of the prostate: 10 year results, in Hilaris B, Nori D (eds): *Brachytherapy Update 1986: Syllabus of the Postgraduate Course Jointly Sponsored by the Brachytherapy Service, Department of Radiation Oncology, Memorial Sloan-Kettering Cancer Center, and the Brachytherapy Oncology Association*. New York, Memorial Sloan-Kettering Cancer Center, 1986, pp. 67–77.
- 16 Cesium-131 Radioactive Isotope Seed From IsoRay Medical Spotlighted at 48th Annual AAPM Meeting; Breakthrough Offers Aggressive New Option for Treatment of Prostate Cancer. *Business Wire* 28 June 2006.
- 17 Chen Z, Deng J, Roberts K, Nath R. Potential impact of prostate edema on the dosimetry of permanent seed implants using the new 131Cs (model CS-1) seeds. *Med Phys*. 2006 Apr; 33(4): 968–75.
- 18 King CR. LDR vs HDR brachytherapy for localized prostate cancer – the view from radiobiological models. *Brachytherapy* 2002, 1(4), 219–226(8).
- 19 Grills IS, Martinez AA, Hollander M, Huang R, Goldman K, Chen PY, Gustafson GS
High dose rate brachytherapy as prostate cancer monotherapy reduces toxicity compared to low dose rate palladium seeds. *J urol*. 2004 Mar;171(3):1098–104.
- 20 Theodorescu D, Mellon P, Krupski TL. Prostate Cancer: Brachytherapy (Radioactive Seed Implantation Therapy). In: www.emedicine.com/med/topic3147.htm#section~pictures August 20, 2004.
- 21 Garbaulet A, Potter R, Mazon JJ, Meertens H, Van Limbergen E. The GEC ESTRO Handbook of Brachytherapy, Brussels, 2002, Chapter 20, 473–480.
- 22 Randy V, Heysek, MD, FACRO. Modern Brachytherapy for treatment of prostate cancer. *Cancer Control* Jul 2007, Vol 14, No.3.
- 23 Leibel SA, Phillips TL. *Textbook of Radiation Oncology*, Second Edition 2004, Chapter 45, 988–1000.
- 24 Theodorescu D, Gillenwater JY, Koutrouvelis PG. Prostatourethral-rectal fistula after prostate brachytherapy. *Cancer* 2000, 15; 89(10): 2085–91.
- 25 Wallner K, Blasko J, Dattoli MJ. *Prostate Brachytherapy Made Complicated*. 1st ed. Seattle, Wash: Smart Medicine; 1997.
- 26 Polascik TJ, Pound CR, DeWeese TL, Walsh PC. Comparison of radical prostatectomy and iodine 125 interstitial radiotherapy for the treatment of clinically localized prostate cancer: a 7-year biochemical (PSA) progression analysis. *Urology* 1998; 51(6): 884–9; discussion 889–90.
- 27 Wallner K, Roy J, Zelefsky M et al. Short-term freedom from disease progression after I-125 prostate implantation. *Int J Radiat Oncol Biol Phys* 1994; 30: 405–409.
- 28 Kaye KW, Olson DJ, Payne JT. Detailed preliminary analysis of 125-Iodine implantation for localized prostate cancer using percutaneous approach. *J Urol* 1995; 153: 1020–1025.
- 29 Stone NN, Stock RG. Reduction of pulmonary migration of permanent interstitial sources in patients undergoing prostate brachytherapy. *Urol* 2005; 66(1): 119–23.
- 30 Kunos CA, Resnick MI, Kinsella TJ, Ellis RJ. Migration of implanted free radioactive seeds for adenocarcinoma of the prostate using a Mick applicator. *Brachytherapy* 2004; 3(2): 71–7.
- 31 Cattani F, Vavassori A, Polo A et al. Radiation exposure after permanent prostate brachytherapy. *Radioth Oncol* 2006; 79(1):65–9.
- 32 Zelefsky MJ, Yamada Y, Cohen GJ et al. Five-year outcome of intraoperative conformal permanent I-125 interstitial implantation for patients with clinically localized prostate cancer. *Int J Radiat Oncol Biol Phys* 2007 1; 67(1): 65–70.
- 33 Guedea F, Aguilo F, Polo A et al. Early biochemical outcomes following permanent interstitial brachytherapy as monotherapy in 1050 patients with clinical T1-T2 prostate cancer. *Radioth Oncol* 2006; 80(1): 57–61.
- 34 Merrick GS, Wallner KE, Butler WM, Galbreath RW, Allen ZA, Adamovich E, True L. Brachytherapy aged < or = 54 years with clinically localized prostate cancer. *BJU Int*. 2006 Aug; 98(2):324–8.

- 35 Merrick GS, Butler WM, Lief JH, Galbreath RW, Adamovich E. Biochemical outcome for hormone-naive patients with high-risk prostate cancer managed with permanent interstitial brachytherapy and supplemental external-beam radiation. *Cancer J* 2002; 8(4): 322-7.
- 36 Bladou F, Salem N, Simonian-Sauve M et al. Permanent iodine 125 implant brachytherapy in localized prostate cancer: results of the first 4 years of experience. *Prog Urol* 2004; 14(3): 345-52.
- 37 Radge H, Grado GL, Nadir BS. Brachytherapy for clinically localized prostate cancer: thirteen-year disease-free survival of 769 consecutive prostate cancer patients treated with permanent implants alone. *Arch Esp Urol* 2001; 54(7): 739-47.
- 38 Sharkey J, Chovnick SD, Behar RJ et al. Minimally invasive treatment for localized adenocarcinoma of the prostate: review of 1048 patients treated with ultrasound-guided palladium-103 brachytherapy. *J Endourol* 2000; 14(4): 343-50.
- 39 Merrick GS, Butler WM, Wallner K et al. Permanent prostate brachytherapy-induced morbidity in patients with grade II and III obesity. *Urology* 2002; 60(1): 104-8.
- 40 Kollmeier MA, Stock RG, Stone N. Biochemical outcomes after prostate brachytherapy with 5-year minimal follow-up: importance of patient selection and implant quality. *Int J Radiat Oncol Biol Phys* 2003; 57(3): 645-53.
- 41 Prada PJ, Hevia M, Juan G et al. I-125 low dose rate brachytherapy in localized prostate cancer. Preliminary results after 5 years. *Arch Esp Urol* 2005; 58(3): 213-26.
- 42 Merrick GS, Butler WM, Wallner KE, Galbreath RW, Adamovich E. Permanent interstitial brachytherapy in younger patients with clinically organ-confined prostate cancer. *Urology* 2004; 64(4): 754-9.
- 43 Stock RG, Stone NN, De Wyngaert JK, Lavagnini P, Unger PD. Prostate specific antigen findings and biopsy results following interactive ultrasound guided transperineal brachytherapy for early stage prostate carcinoma. *Cancer* 1996; 77(11): 2386-92.
- 44 Wallner K, Merrick G, True L et al. 20 Gy versus 44 Gy supplemental beam radiation with Pd-103 prostate brachytherapy: preliminary biochemical outcomes from a prospective randomized multi-center trial. *Radiother Oncol* 2005; 75(3): 307-10.
- 45 Sylvester JE, Grimm PD, Blasko JC et al. 15-Year biochemical relapse free survival in clinical Stage T1-T3 prostate cancer following combined external beam radiotherapy and brachytherapy; Seattle experience. *Int J Radiat Oncol Biol Phys* 2007; 67(1): 57-64.
- 46 Sherertz T, Wallner K, Merrick G et al. The prognostic significance of Gleason pattern 5 in prostate cancer patients treated with Pd 103 plus beam radiation therapy. *Cancer J* 2004; 10(5): 301-6.
- 47 Stock RG, Stone NN. Preliminary toxicity and prostate-specific antigen response of a Phase I/II trial of neoadjuvant hormonal therapy, 103Pd brachytherapy, and three-dimensional conformal external beam irradiation in the treatment of locally advanced prostate cancer. *Brachytherapy* 2002; 1(1): 2-10.
- 48 Orio P, Wallner K, Merrick G et al. Dosimetric parameters as predictive factors for biochemical control in patients with higher risk prostate cancer treated with Pd-103 and supplemental beam radiation. *Int J Radiat Oncol Biol Phys* 2007; 67(2): 342-6.
- 49 Peschel RE, Colberg JW, Chen Z, Nath R, Wilson LD. Iodine 125 versus palladium 103 implants for prostate cancer: clinical outcomes and complications. *Cancer J* 2004; 10(3): 170-4.
- 50 Merrick GS, Butler WM, Wallner KE et al. Impact of supplemental external beam radiotherapy and/or androgen deprivation therapy on biochemical outcome after permanent prostate brachytherapy. *Int J Radiat Oncol Biol Phys* 2005; 61(1): 32-43.
- 51 Shah JN, Ennis RD. Rectal toxicity profile after transperineal interstitial permanent prostate brachytherapy: use of comprehensive toxicity scoring system and identification of rectal dosimetric toxicity predictors. *Int J Radiat Oncol Biol Phys* 2006; 64: 817-824.
- 52 Merrick GS, Butler WM, Galbreath RW, Stipetich RL, Abel LJ, Lief JH. Erectile function after permanent prostate brachytherapy. *Int J Radiat Oncol Biol Phys* 2002; 52: 893-902.
- 53 Mc Elveen TL, Waterman FM, Hayeon K, Dicker AP. Factors predicting for urinary incontinence after prostate brachytherapy. *Int J Radiat Oncol Biol Phys* 2004; 57: 1395-1404.
- 54 Battermann JJ. J-125 implantation for localized prostate cancer: the Utrecht University experience. *Radiother Oncol* 2000; 57: 269-272.
- 55 Blank L, Gonzalez DG, de Reijke TM, Dobhoiwala NF, Koedooder K. Brachytherapy with trans-